

ALTERNATORS
ALXION STK
for Wind Turbines



ALXION

Automatique
& Productique

**PM Brushless Alternators
for Direct Drive**

ALXION

Automatique & Productique

STK permanent magnets frameless alternators for Direct Drive

The range of STK Permanent Magnet frameless alternators addresses the applications of Wind Turbine generators in low and medium power needing the highest power-to-weight ratio in Direct Drive without gear for matching cost-effective solutions. The range of permanent magnet frameless alternators STK includes 6 sizes from 145 mm up to 800 mm available in four different lengths per size and two standard rated speeds.



Main characteristics:

- ➔ Rated power from 200 W up to 99 kW depending on size and rated speeds.
- ➔ Rated speeds from 80 RPM up to 1500 RPM.
- ➔ Six overall diameters from 145 mm up to 795 mm.
- ➔ Internal diameter from 56 mm up to 630 mm.
- ➔ Various available voltages up to 500 Vac.

Assets:

- ➔ No speed multiplier, no gear
- ➔ No maintenance
- ➔ Highest power-to-weight ratio in Direct Drive
- ➔ Simplification of mechanical design
- ➔ Easy mechanical interface
- ➔ Cost optimization

Those alternators supply an electrical power of 1.5 KW, 2 KW and 6 KW depending on the models, respectively 190 STK 2M, 190 STK 3M and 400 STK 3M.

They equip wind turbines with relatively low power which supply lighthouses, beacons, houses and plants far away from distribution networks.

STK permanent magnets frameless brushless alternators 500 STK 4M and 500 STK 6M equip wind turbines with electrical power up to 15 KW and 20 KW.

Usually, this type of wind turbines were equipped with asynchronous generators requiring to multiply the speed of rotor blades in order to produce the desired electrical power. Permanent magnets alternators such as ALXION STK are very compact compared to asynchronous generators, and allow a very simplified mechanical integration thanks to their direct driving of rotor blades. Furthermore, the efficiency with permanent magnets synchronous alternators is higher than the one resulting from asynchronous generators.

Wind turbine applications should grow considerably in the next years due to the international incentive plans for substituting soft renewable energies to fossil energies: the cost of 1 kilowatt per hour produced by wind energy is the less expensive among the soft energies.

TECHNICAL CHARACTERISTICS

145 STK ALTERNATORS

		145STK2M		145STK4M		145STK6M		145STK8M	
Rated speed	Rpm	650	1500	650	1500	650	1500	650	1500
Rated power (1)(2)	W	571	1683	1285	3250	1937	4163	2539	5550
Current at rated speed (1)	Amps	1.4	4.2	3.2	8.1	4.9	10.4	6.4	13.9
Voltage at rated power (1)(2)(3)	V	133	133	133	133	133	133	133	133
Power at half speed (1)(2)	W	204	667	460	1538	769	2296	1016	3007
Phase resistance at 20°C	Ohm	20.7	4.55	8.65	1.36	4.17	0.59	3.00	0.42
Phase inductance	mH	106.55	23.4	61.99	9.81	34.01	4.9	26.57	3.67
Phase emf at 20°C (4)	V	210.5	228.6	227.1	206.7	206.3	179.9	209.8	180.0
Rotor inertia	10 ⁻³ Kg.m ²	1.28	1.28	2.24	2.24	3.19	3.19	4.14	4.14
Weight	Kg	6.2	6.2	10.4	10.4	14.5	14.5	18.7	18.7
Power cable square section	mm ²	4x1.5	4x1.5	4x1.5	4x1.5	4x1.5	4x1.5	4x1.5	4x1.5

145 STK Generators Power - Speed

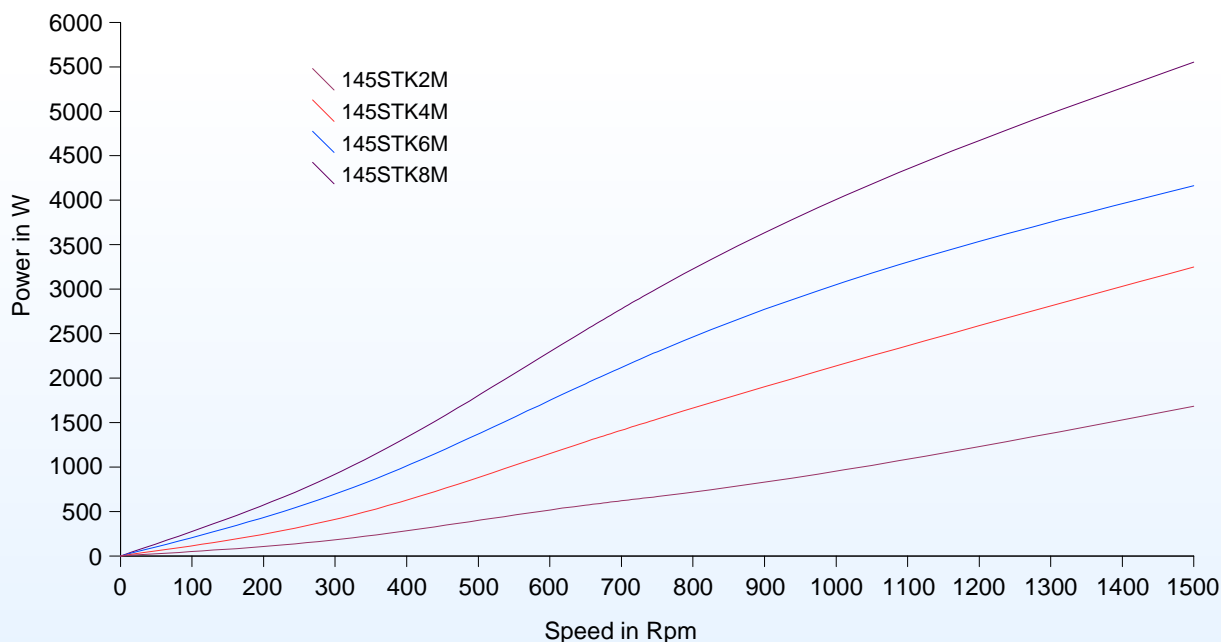

(1) Ambient temperature 40°C

Wind speed 10 m/s

Winding temperature rise < 100°C

Stator housing in contact with the ambient air or integral on all its peripheral area with a metallic armature in contact with the ambient air

Stator housing secured on a metallic frame getting an area equal to twice the cross section of the housing

(2) Operation with unitary power factor

(3) Single voltage, voltage is 230Vac phase to phase. Voltage level may be adapted according to the application

(4) Alternator at no load and rated speed

(5) For current at rated power

ALTERNATORS 145 STK

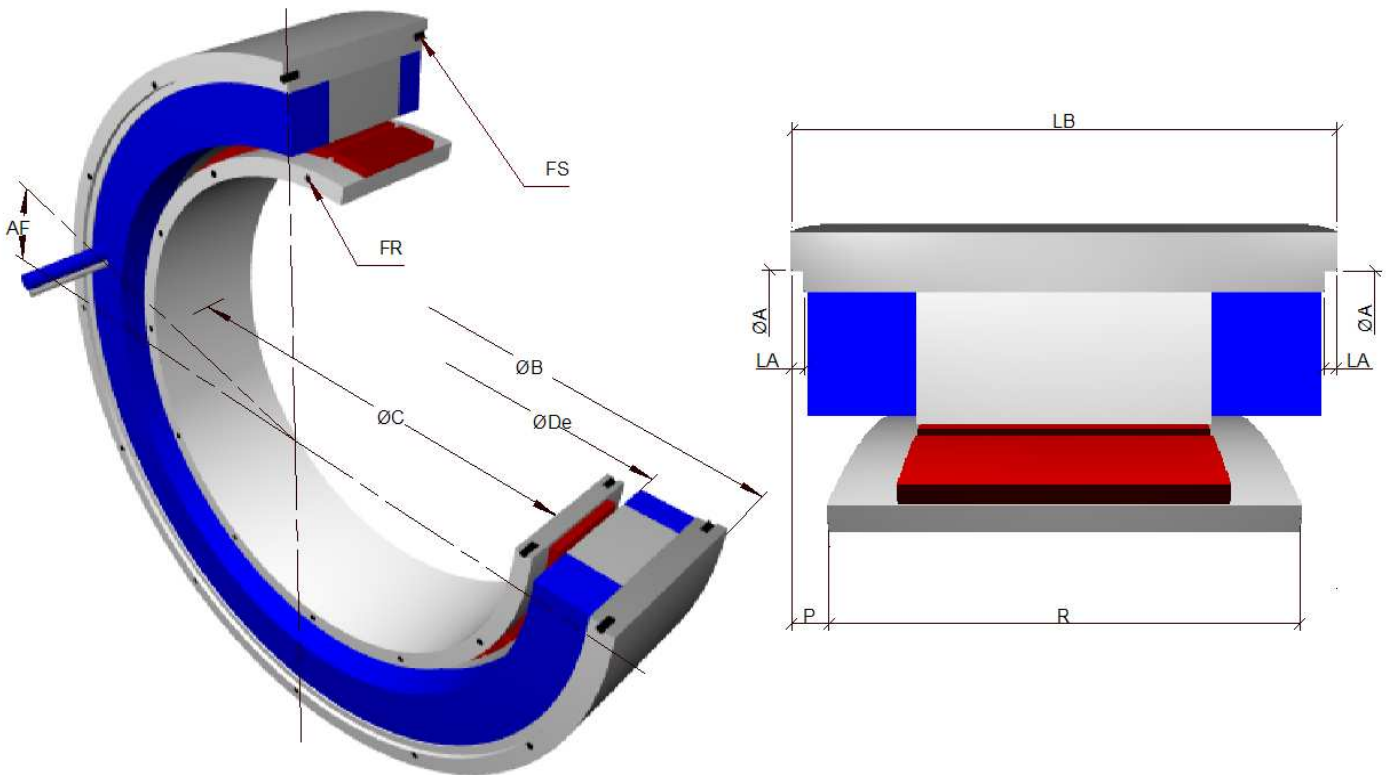

		145STK1M	145STK2M	145STK3M	145STK4M	145STK5M	145STK6M	145STK7M	145STK8M
Housing internal centering diameter	A H8	130	130	130	130	130	130	130	130
Angle wire output / tapped holes	AF	22°30'	22°30'	22°30'	22°30'	22°30'	22°30'	22°30'	22°30'
Housing external centering diameter (natural convection)	B H8	145	145	145	145	145	145	145	145
Rotoric internal centering diameter	C H7	56	56	56	56	56	56	56	56
Housing internal diameter	De	78,5	78,5	78,5	78,5	78,5	78,5	78,5	78,5
Rotoric fixation holes	FR	8xM5 on Ø63	8xM5 on Ø63	8xM5 on Ø63	8xM5 on Ø63	8xM5 on Ø63	8xM5 on Ø63	8xM5 on Ø63	8xM5 on Ø63
Housing fixation holes	FS	8xM5 on Ø136	8xM5 on Ø136	8xM5 on Ø136	8xM5 on Ø136	8xM5 on Ø136	8xM5 on Ø136	8xM5 on Ø136	8xM5 on Ø136
Depth of housing internal centering diameter	LA	2	2	2	2	2	2	2	2
Housing length	LB ±0.15	92	119	146	173	200	227	254	281
Alignment rotor / housing	P ± 0.1	20,5	20,5	20,5	20,5	20,5	20,5	20,5	20,5
Maximum rotoric contact diameter	Pmax	75	75	75	75	75	75	75	75
Rotor length	R +0.15	59	86	113	140	167	194	221	248

INTEGRATION :

- ✓ The cables are made of PU, class 6, foreseen for cable-bearing chains, 2 mt standard length, copper square section according rated current.
- ✓ Rotor / housing alignment (P) has to be executed within +/- 0.1 mm. Optionally, we can supply a mounting tool for achieving that alignment in case of assembly without possibility of accurate alignment.
- ✓ Thermal device cable consists of a shielded pair 2x2x0.25mm² section, 7mm external diameter.
- ✓ (De) represents:
 - 1- The maximum diameter passing inside the housing.
 - 2- The maximum diameter necessary for rotor assembly.
- ✓ (Pmax) diameter for pieces in contact with the rotor must never be exceeded.
- ✓ Tapped holes on each side of rotor and housing are angularly aligned.
- ✓ Cable positioning (AF) is theoretical. Leave a free room with a +/- 10 arc degrees tolerance around that position, on a 50 mm height from the housing side, for avoiding to force the cables at the alternator output.
- ✓ When designing the assembly, take care to insure a perfect contact between housing and user's bore for avoiding thermal problems.
- ✓ For housing mounting, use either external centering diameter (B) or internal centering diameters (A).
- ✓ For execution tolerances (perpendicularity, concentricity...), please consult us.

A full integration handbook can be supplied to our customers upon request
 For further information or specific request about our alternators, feel free to contact us.

TECHNICAL CHARACTERISTICS

190 STK ALTERNATORS

		190STK2M		190STK4M		190STK6M		190STK8M	
Rated speed	Rpm	500	1500	500	1500	500	1000	500	1000
Rated power (1)(2)	W	1120	3593	2298	5747	3456	7031	4580	8506
Current at rated speed (1)	Amps	2.8	9.0	5.8	14.4	8.7	17.6	11.5	21.3
Voltage at rated power (1)(2)(3)	V	133	133	133	133	133	133	133	133
Power at half speed (1)(2)	W	436	1730	954	3600	1461	3456	1947	4580
Phase resistance at 20°C	Ohm	8.39	0.82	2.98	0.25	1.75	0.42	1.25	0.26
Phase inductance	mH	84.83	8.42	40.61	3.54	27.11	6.61	20.67	4.39
Phase emf at 20°C (4)	V	205.9	192.6	200.8	176.2	200.2	196.8	201.5	185.2
Rotor inertia	10 ⁻³ Kg.m ²	4.12	4.12	7.5	7.5	10.88	10.88	14.26	14.26
Weight	Kg	13	13	22	22	31	31	40	40
Power cable square section	mm ²	4x1.5	4x1.5	4x1.5	4x1.5	4x1.5	4x2.5	4x1.5	4x2.5

190 STK Generators Power - Speed

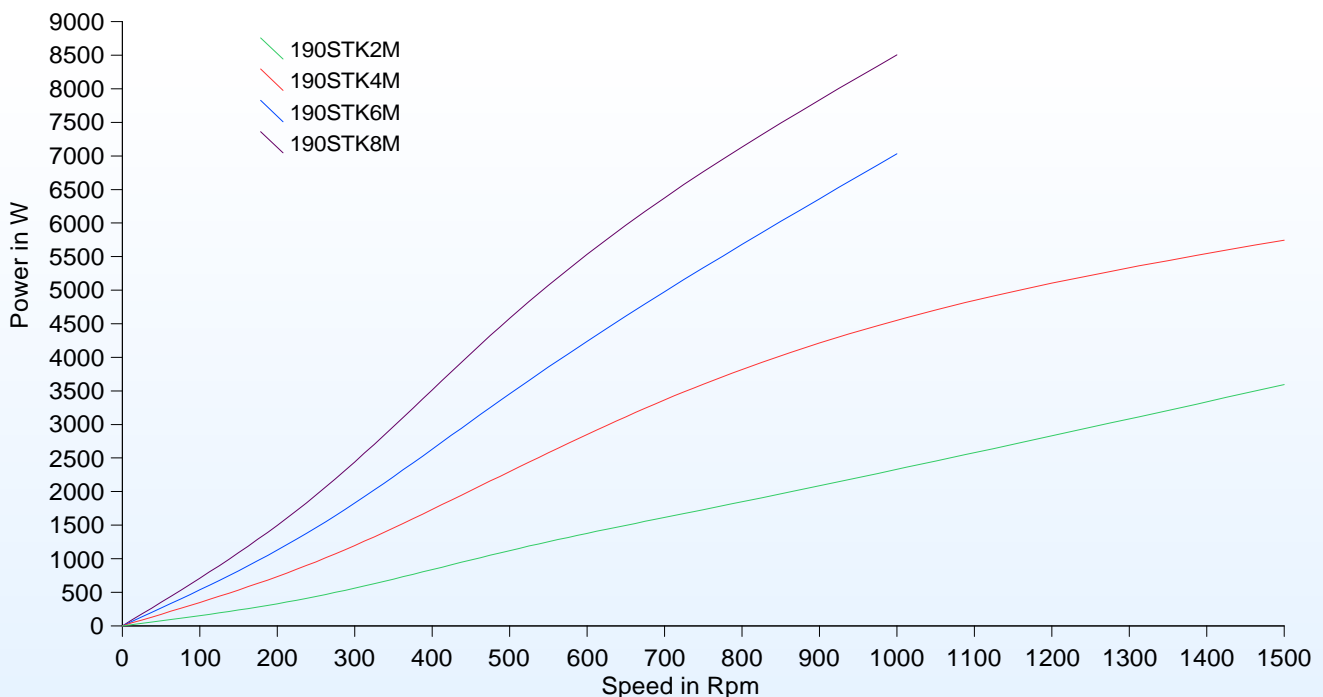

- (1) Ambient temperature 40°C
 Wind speed 10 m/s
 Winding temperature rise < 100°C
 Stator housing in contact with the ambient air or integral on all its peripheral area with a metallic armature in contact with the ambient air
 Stator housing secured on a metallic frame getting an area equal to twice the cross section of the housing
- (2) Operation with unitary power factor
- (3) Single voltage, voltage is 230Vac phase to phase. Voltage level may be adapted according to the application
- (4) Alternator at no load and rated speed
- (5) For current at rated power

ALTERNATORS 190 STK

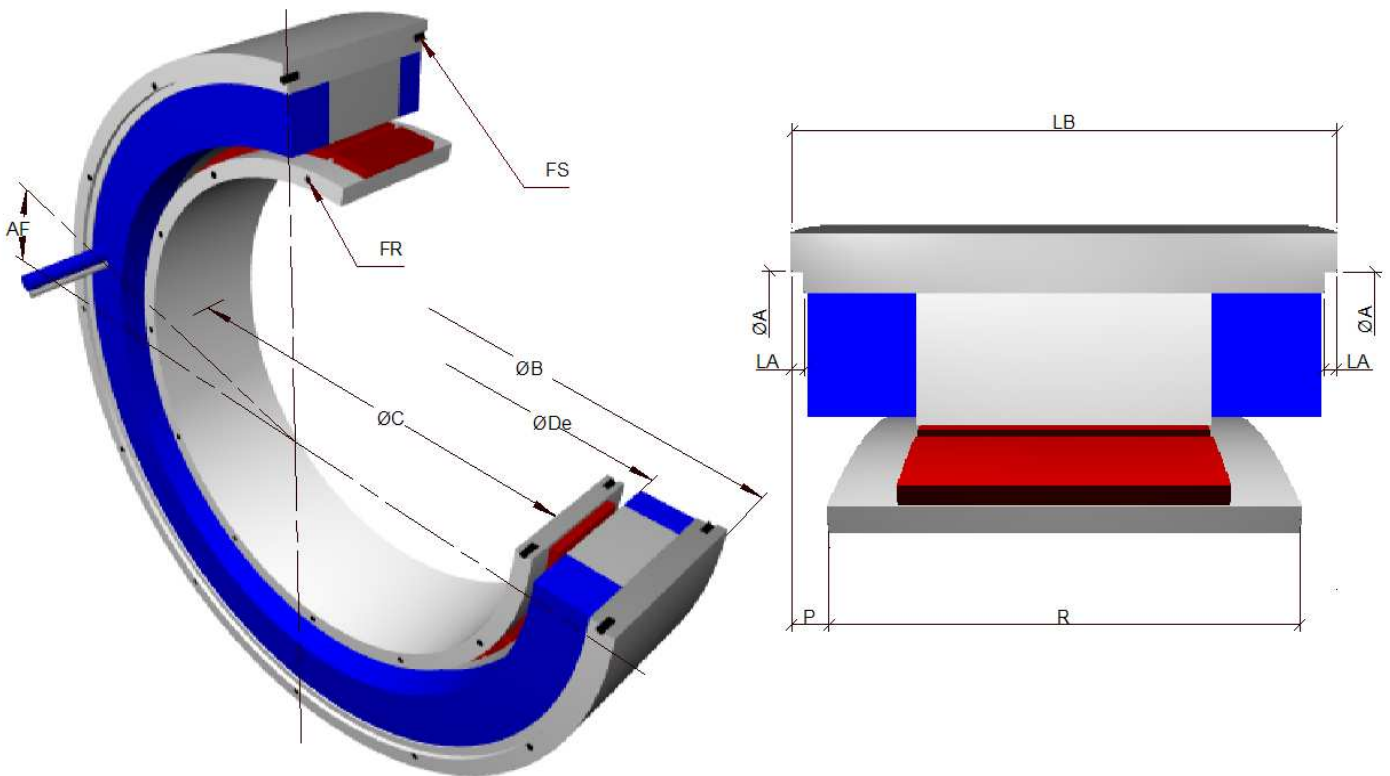

		190STK1M	190STK2M	190STK3M	190STK4M	190STK5M	190STK6M	190STK7M	190STK8M
Housing internal centering diameter	A H8	172	172	172	172	172	172	172	172
Angle wire output / tapped holes	AF	22°30'	22°30'	22°30'	22°30'	22°30'	22°30'	22°30'	22°30'
Housing external centering diameter (natural convection)	B H7	190	190	190	190	190	190	190	190
Rotoric internal centering diameter	C H7	72	72	72	72	72	72	72	72
Housing internal diameter	De	98	98	98	98	98	98	98	98
Rotoric fixation holes	FR	8xM5 on Ø80	8xM5 on Ø80	8xM5 on Ø80	8xM5 on Ø80	8xM5 on Ø80	8xM5 on Ø80	8xM5 on Ø80	8xM5 on Ø80
Housing fixation holes	FS	8xM5 on Ø180	8xM5 on Ø180	8xM5 on Ø180	8xM5 on Ø180	8xM5 on Ø180	8xM5 on Ø180	8xM5 on Ø180	8xM5 on Ø180
Depth of housing internal centering diameter	LA	2	2	2	2	2	2	2	2
Housing length	LB ±0.15	103.75	140	176.25	212.5	248.75	285	321.25	357.5
Alignment rotor / housing	P ± 0.1	23	23	23	23	23	23	23	23
Maximum rotoric contact diameter	Pmax	94	94	94	94	94	94	94	94
Rotor length	R +0.15	68.25	104.5	140.75	177	213.25	249.5	285.75	322

INTEGRATION :

- ✓ The cables are made of PU, class 6, foreseen for cable-bearing chains, 2 mt standard length, copper square section according rated current.
- ✓ Rotor / housing alignment (P) has to be executed within +/- 0.1 mm. Optionally, we can supply a mounting tool for achieving that alignment in case of assembly without possibility of accurate alignment.
- ✓ Thermal device cable consists of a shielded pair 2x2x0.25mm² section, 7mm external diameter.
- ✓ (De) represents:
 - 1- The maximum diameter passing inside the housing.
 - 2- The maximum diameter necessary for rotor assembly.
- ✓ (Pmax) diameter for pieces in contact with the rotor must never be exceeded.
- ✓ Tapped holes on each side of rotor and housing are angularly aligned.
- ✓ Cable positioning (AF) is theoretical. Leave a free room with a +/- 10 arc degrees tolerance around that position, on a 50 mm height from the housing side, for avoiding to force the cables at the alternator output.
- ✓ When designing the assembly, take care to insure a perfect contact between housing and user's bore for avoiding thermal problems.
- ✓ For housing mounting, use either external centering diameter (B) or internal centering diameters (A).
- ✓ For execution tolerances (perpendicularity, concentricity...), please consult us.

A full integration handbook can be supplied to our customers upon request
 For further information or specific request about our alternators, feel free to contact us.

TECHNICAL CHARACTERISTICS

300 STK ALTERNATORS

		300STK2M		300STK4M		300STK6M		300STK8M	
		350	800	350	800	350	800	350	600
Rated speed	Rpm	350	800	350	800	350	800	350	600
Rated power (1)(2)	W	3174	8413	6627	13942	9573	17106	12683	19424
Current at rated speed (1)	Amps	7.9	21.1	16.6	34.9	24.0	42.9	31.8	48.7
Voltage at rated power (1)(2)(3)	V	133	133	133	133	133	133	133	133
Power at half speed (1)(2)	W	1297	3745	2729	7741	4136	11126	5506	10632
Phase resistance at 20°C	Ohm	2.41	0.47	0.99	0.15	0.53	0.08	0.37	0.11
Phase inductance	mH	15.1	3,04	8.5	1,28	5,08	0,78	3,86	1,11
Phase emf at 20°C (4)	V	178.6	180.4	186.9	165.5	177.4	159.8	178.6	164.1
Rotor inertia	10 ⁻³ Kg.m ²	52.7	52.7	105.5	105.5	158.2	158.2	211	211
Weight	Kg	18	18	31	31	44	44	57	57
Power cable square section	mm ²	4x1.5	4x2.5	4x1.5	4x6	4x4	4x10	4x6	4x10

300 STK Generators Power - Speed

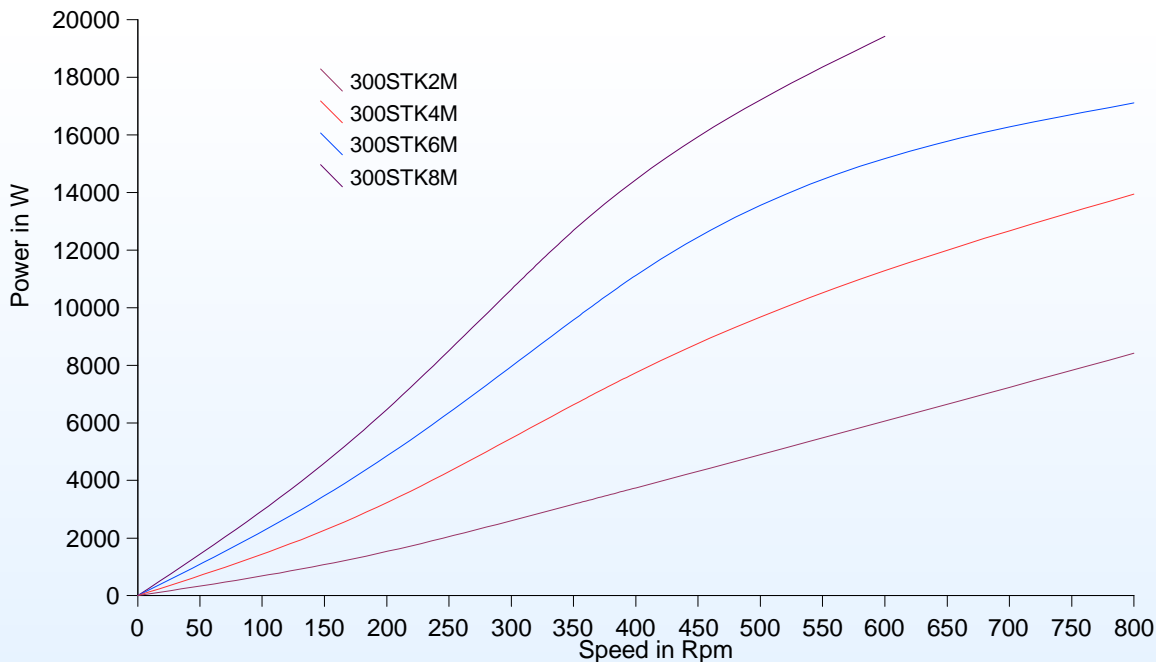

- (1) Ambient temperature 40°C
 Wind speed 10 m/s
 Winding temperature rise < 100°C
 Stator housing in contact with the ambient air or integral on all its peripheral area with a metallic armature in contact with the ambient air
 Stator housing secured on a metallic frame getting an area equal to twice the cross section of the housing
- (2) Operation with unitary power factor
- (3) Single voltage, voltage is 230Vac phase to phase. Voltage level may be adapted according to the application
- (4) Alternator at no load and rated speed
- (5) For current at rated power

ALTERNATORS 300 STK

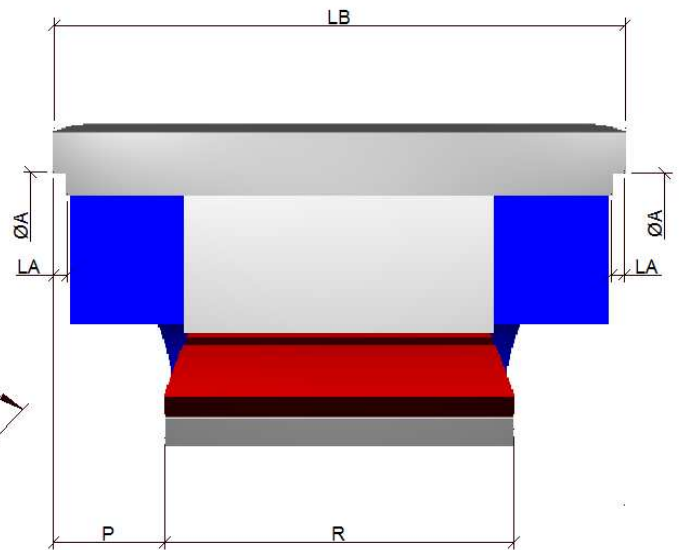
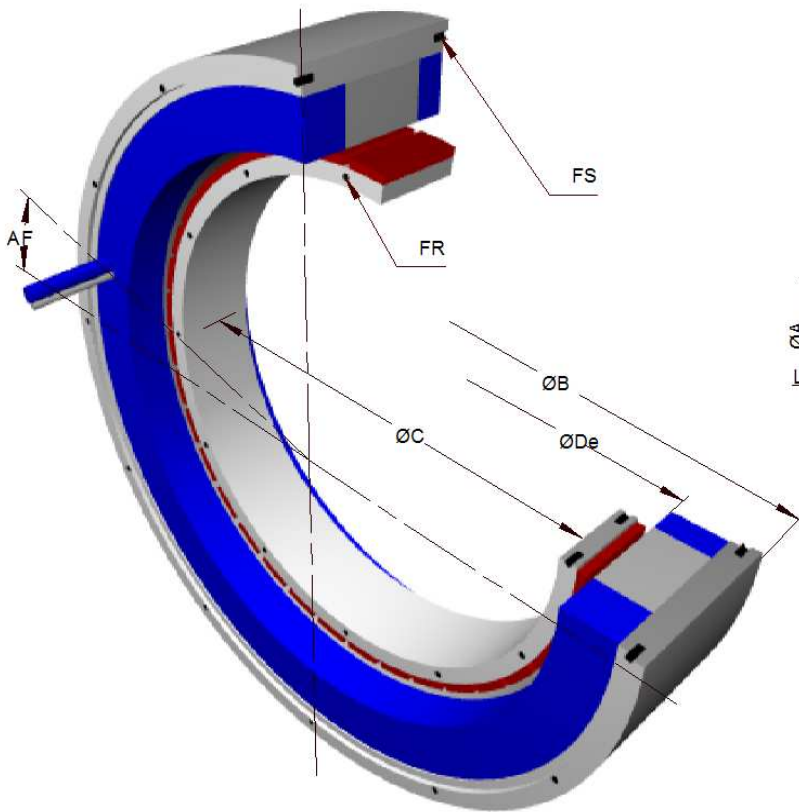

		300STK1M	300STK2M	300STK3M	300STK4M	300STK5M	300STK6M	300STK7M	300STK8M
Housing internal centering diameter	A H8	282	282	282	282	282	282	282	282
Angle wire output / tapped holes	AF	15°	15°	15°	15°	15°	15°	15°	15°
Housing external centering diameter (natural convection)	B H8	303	303	303	303	303	303	303	303
Rotoric internal centering diameter	C H7	190	190	190	190	190	190	190	190
Housing internal diameter	De	228	228	228	228	228	228	228	228
Rotoric fixation holes	FR	12xM5 on Ø199	12xM5 on Ø199	12xM5 on Ø199	12xM5 on Ø199	12xM5 on Ø199	12xM5 on Ø199	12xM5 on Ø199	12xM5 on Ø199
Housing fixation holes	FS	12xM5 on Ø290	12xM5 on Ø290	12xM5 on Ø290	12xM5 on Ø290	12xM5 on Ø290	12xM5 on Ø290	12xM5 on Ø290	12xM5 on Ø290
Depth of housing internal centering diameter	LA	3	3	3	3	3	3	3	3
Housing length	LB ±0.15	87.5	115	142.5 (172.5)	170 (200)	197.5 (227.5)	225 (255)	252.5 (282.5)	280 (310)
Alignment rotor / housing	P ± 0.1	34.5	34.5	34.5 (64.5)	34.5 (64.5)	34.5 (64.5)	34.5 (64.5)	34.5 (64.5)	34.5 (64.5)
Maximum rotoric contact diameter	Pmax	213	213	213	213	213	213	213	213
Rotor length	R +0.15	27.5	55	82.5	110	137.5	165	192.5	220

INTEGRATION :

- ✓ The cables are made of PU, class 6, foreseen for cable-bearing chains, 2 mt standard length, copper square section according rated current.
- ✓ Rotor / housing alignment (P) has to be executed within +/- 0.1 mm. Optionally, we can supply a mounting tool for achieving that alignment in case of assembly without possibility of accurate alignment.
- ✓ Thermal device cable consists of a shielded pair 2x2x0.25mm² section, 7mm external diameter.
- ✓ (De) represents:
 - 1- The maximum diameter passing inside the housing.
 - 2- The maximum diameter necessary for rotor assembly.
- ✓ (Pmax) diameter for pieces in contact with the rotor must never be exceeded.
- ✓ Tapped holes on each side of rotor and housing are angularly aligned.
- ✓ Cable positioning (AF) is theoretical. Leave a free room with a +/- 10 arc degrees tolerance around that position, on a 50 mm height from the housing side, for avoiding to force the cables at the alternator output.
- ✓ When designing the assembly, take care to insure a perfect contact between housing and user's bore for avoiding thermal problems.
- ✓ For housing mounting, use either external centering diameter (B) or internal centering diameters (A).
- ✓ For execution tolerances (perpendicularity, concentricity...), please consult us.
- ✓ In red in the table : P, LB, J4 and E3 are 30mm wider when the nominal current is greater than 72 amps (four single wires output)

A full integration handbook can be supplied to our customers upon request
 For further information or specific request about our alternators, feel free to contact us.

TECHNICAL CHARACTERISTICS

400 STK ALTERNATORS

		400STK2M		400STK3M		400STK4M		400STK6M		400STK8M	
Rated speed	Rpm	220	800	220	800	220	800	220	600	220	500
Rated power (1)(2)	W	4319	18088	6618	23503	8747	24796	13357	29526	17429	33813
Current at rated speed (1)	Amps	10.8	45.3	16.3	59	21.9	62.2	33.5	74.0	43.7	84.7
Voltage at rated power (1)(2)(3)	V	133	133	133	133	133	133	133	133	133	133
Power at half speed (1)(2)	W	1580	8608	2656	12500	3666	15000	5583	18000	7485	20141
Phase resistance at 20°C	Ohm	2.44	0.14	1.63	0.1	0.65	0.04	0.44	0.04	0.29	0.05
Phase inductance	mH	21.5	1.23	0.013	0.001	8.77	0.52	6.3	0.62	4.48	0.69
Phase emf at 20°C (4)	V	199.8	173.6	190.3	164.7	180.5	159.1	186.2	160.4	181.5	162.1
Rotor inertia	10 ⁻³ Kg.m ²	163	163	245	245	325	325	488	488	650	650
Weight	Kg	35	35	46	46	58	58	81	81	104	104
Power cable square section	mm ²	4x1.5	4x10	4x4	4x16	4x4	4x16	4x6	4x10	4x10	4x16

400 STK Generators Power - Speed

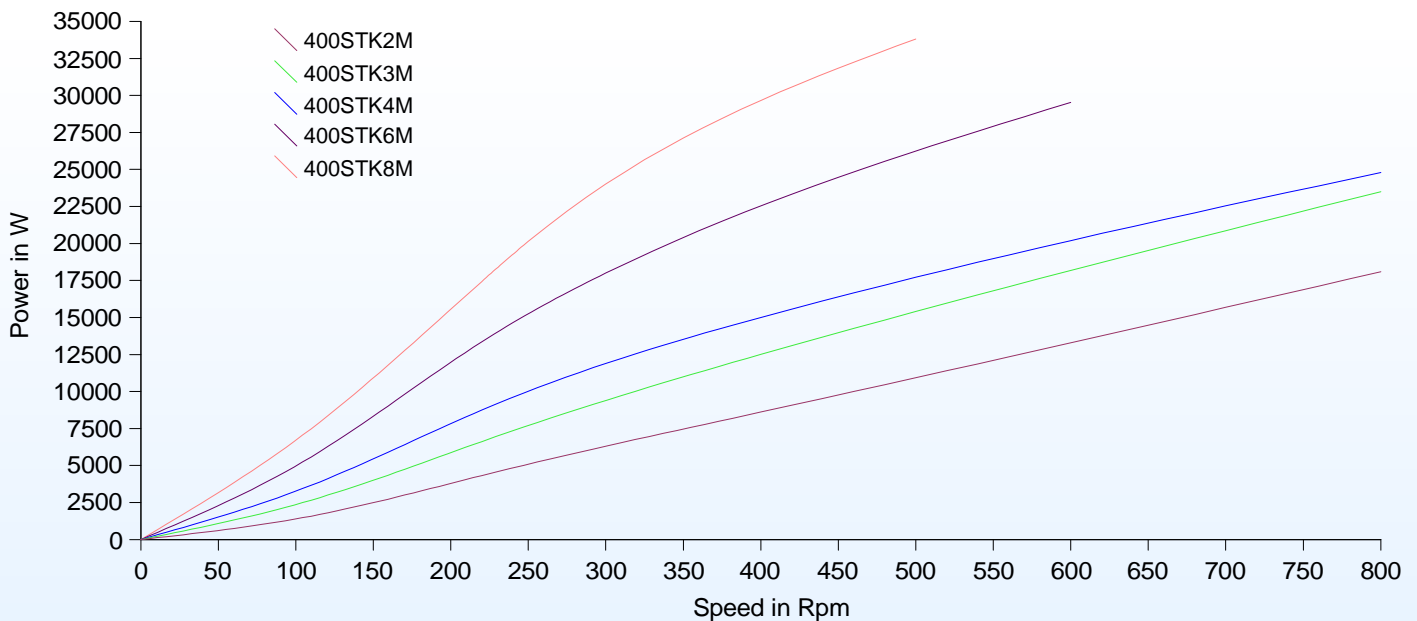

- (1) Ambient temperature 40°C
 Wind speed 10 m/s
 Winding temperature rise < 100°C
 Stator housing in contact with the ambient air or integral on all its peripheral area with a metallic armature in contact with the ambient air
 Stator housing secured on a metallic frame getting an area equal to twice the cross section of the housing
- (2) Operation with unitary power factor
- (3) Single voltage, voltage is 230Vac phase to phase. Voltage level may be adapted according to the application
- (4) Alternator at no load and rated speed

ALTERNATORS 400 STK

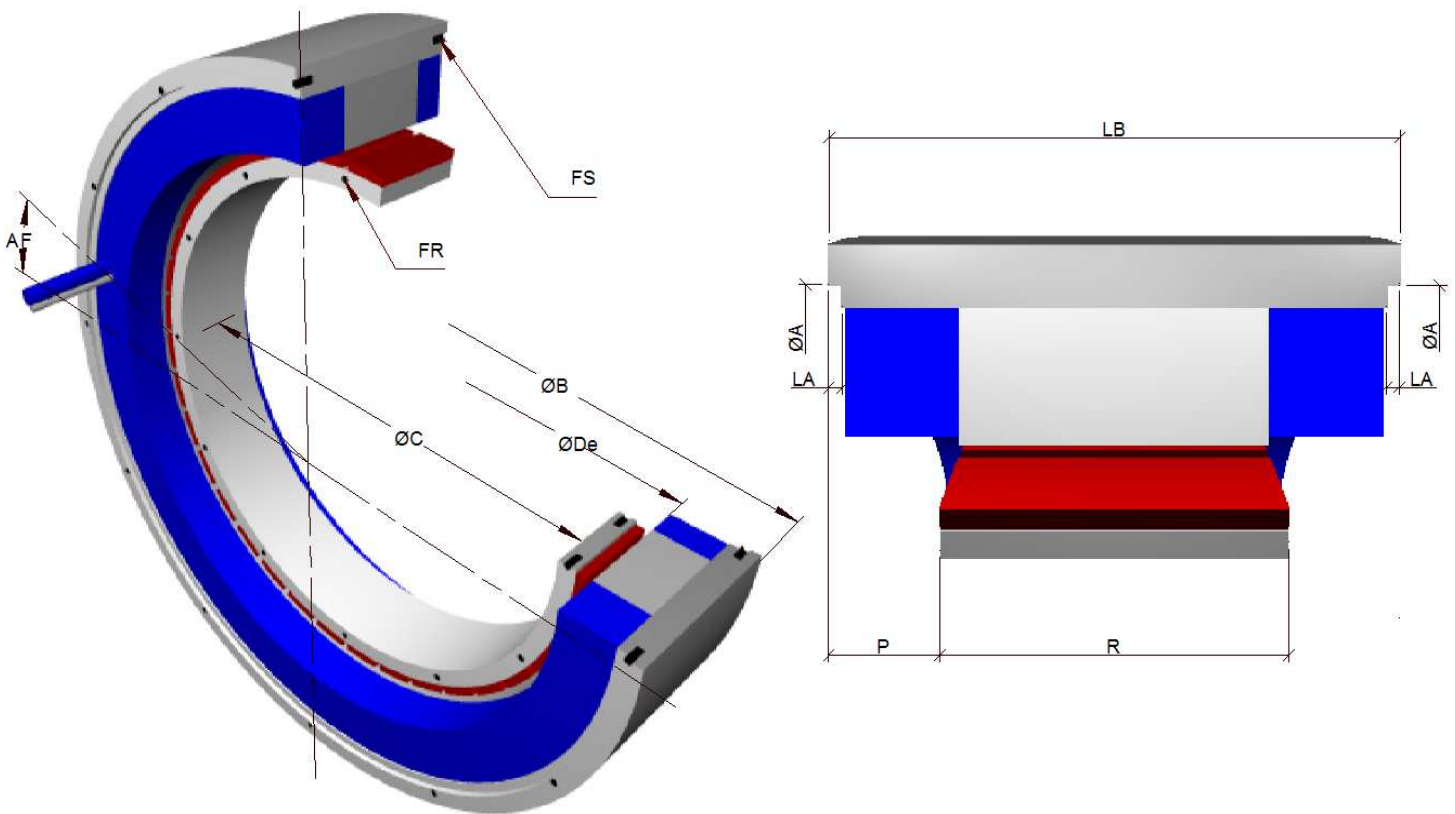

		400STK1M	400STK2M	400STK3M	400STK4M	400STK5M	400STK6M	400STK7M	400STK8M
Housing internal centering diameter	A H8	380	380	380	380	380	380	380	380
Angle wire output / tapped holes	AF	15°	15°	15°	15°	15°	15°	15°	15°
Housing external centering diameter (natural convection)	B Ø	404	404	404	404	404	404	404	404
Rotoric internal centering diameter	C H7	258	258	258	258	258	258	258	258
Housing internal diameter	De	306	306	306	306	306	306	306	306
Rotoric fixation holes	FR	12xM6 on Ø268	12xM6 on Ø268	12xM6 on Ø268	12xM6 on Ø268	12xM6 on Ø268	12xM6 on Ø268	12xM6 on Ø268	12xM6 on Ø268
Housing fixation holes	FS	12xM6 on Ø390	12xM6 on Ø390	12xM6 on Ø390	12xM6 on Ø390	12xM6 on Ø390	12xM6 on Ø390	12xM6 on Ø390	12xM6 on Ø390
Depth of housing internal centering diameter	LA	3	3	3	3	3	3	3	3
Housing length	LB ±0.15	100.5 (130.5)	128 (158)	155.5 (185.5)	183 (213)	210.5 (240.5)	238 (268)	265.5 (295.5)	293 (323)
Alignment rotor / housing	P ± 0.1	39 (69)	39 (69)	39 (69)	39 (69)	39 (69)	39 (69)	39 (69)	39 (69)
Maximum rotoric contact diameter	Pmax	287	287	287	287	287	287	287	287
Rotor length	R +0.15	27.5	55	82.5	110	137.5	165	192.5	220

INTEGRATION :

- ✓ The cables are made of PU, class 6, foreseen for cable-bearing chains, 2 mt standard length, copper square section according rated current.
- ✓ Rotor / housing alignment (P) has to be executed within +/- 0.1 mm. Optionally, we can supply a mounting tool for achieving that alignment in case of assembly without possibility of accurate alignment.
- ✓ Thermal device cable consists of a shielded pair 2x2x0.25mm² section, 7mm external diameter.
- ✓ (De) represents:
 - 1- The maximum diameter passing inside the housing.
 - 2- The maximum diameter necessary for rotor assembly.
- ✓ (Pmax) diameter for pieces in contact with the rotor must never be exceeded.
- ✓ Tapped holes on each side of rotor and housing are angularly aligned.
- ✓ Cable positioning (AF) is theoretical. Leave a free room with a +/- 10 arc degrees tolerance around that position, on a 50 mm height from the housing side, for avoiding to force the cables at the alternator output.
- ✓ When designing the assembly, take care to insure a perfect contact between housing and user's bore for avoiding thermal problems.
- ✓ For housing mounting, use either external centering diameter (B) or internal centering diameters (A).
- ✓ For execution tolerances (perpendicularity, concentricity...), please consult us.
- ✓ In red in the table : P, LB, J4 and E3 are 30mm wider when the nominal current is greater than 72 amps (four single wires output)

A full integration handbook can be supplied to our customers upon request
For further information or specific request about our alternators, feel free to contact us.

TECHNICAL CHARACTERISTICS

500 STK ALTERNATORS

		500STK2M		500STK4M		500STK6M		500STK8M	
Rated speed	Rpm	150	600	150	500	150	450	150	400
Rated power (1)(2)	W	4743	22774	9761	33126	14724	39483	19539	43824
Current at rated speed (1)	Amps	11.9	57.1	24.5	83.0	36.9	99.0	49.0	109.8
Voltage at rated power (1)(2)(3)	V	133	133	133	133	133	133	133	133
Power at half speed (1)(2)	W	1812	10566	4017	18492	6195	23025	8284	26600
Phase resistance at 20°C	Ohm	2.08	0.1	0.71	0.05	0.41	0.04	0.29	0.03
Phase inductance	mH	15.6	0.87	7.41	0.57	4.92	0.45	3.75	0.42
Phase emf at 20°C (4)	V	187.2	175.9	181.7	167.9	180.7	163.5	181.8	162.4
Rotor inertia	10 ⁻³ Kg.m ²	433	433	865	865	1296	1296	1730	1730
Weight	Kg	43	43	73	73	103	103	133	133
Power cable square section	mm ²	4x1.5	4x16	4x4	4x16	4x6	4x25	4x10	4x25

500 STK Generators Power - Speed

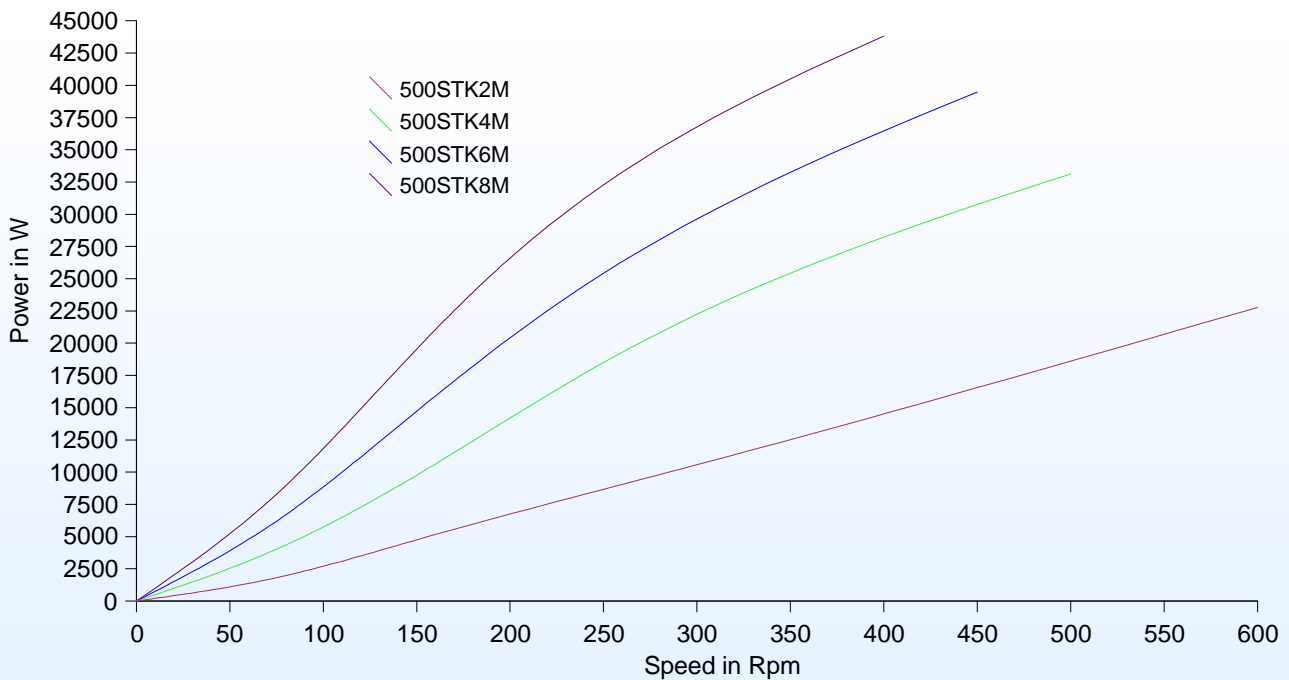

- (1) Ambient temperature 40°C
 Wind speed 10 m/s
 Winding temperature rise < 100°C
 Stator housing in contact with the ambient air or integral on all its peripheral area with a metallic armature in contact with the ambient air
 Stator housing secured on a metallic frame getting an area equal to twice the cross section of the housing
- (2) Operation with unitary power factor
- (3) Single voltage, voltage is 230Vac phase to phase. Voltage level may be adapted according to the application
- (4) Alternator at no load and rated speed

ALTERNATORS 500 STK

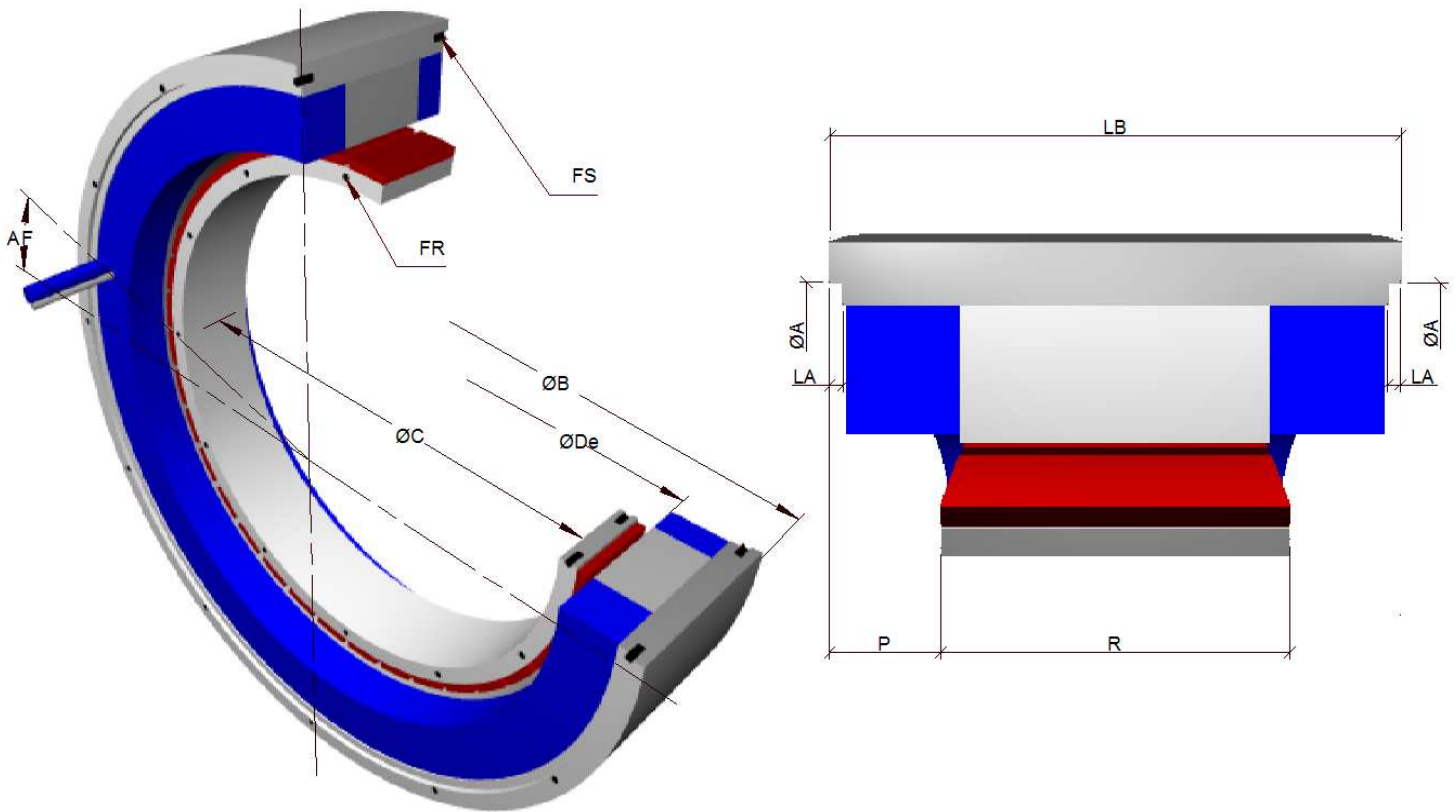

		500STK1M	500STK2M	500STK3M	500STK4M	500STK5M	500STK6M	500STK7M	500STK8M	500STK9M
Housing internal centering diameter	A H8	470	470	470	470	470	470	470	470	470
Angle wire output / tapped holes	AF	15°	15°	15°	15°	15°	15°	15°	15°	15°
Housing external centering diameter (natural convection)	B Ø	502	502	502	502	502	502	502	502	502
Rotoric internal centering diameter	C H7	350	350	350	350	350	350	350	350	350
Housing internal diameter	De	403	403	403	403	403	403	403	403	403
Rotoric fixation holes	FR	12xM8 sur Ø364	12xM8 sur Ø364	12xM8 sur Ø364	12xM8 sur Ø364	12xM8 sur Ø364	12xM8 sur Ø364	12xM8 sur Ø364	12xM8 sur Ø364	12xM8 sur Ø364
Housing fixation holes	FS	12xM8 sur Ø482	12xM8 sur Ø482	12xM8 sur Ø482	12xM8 sur Ø482	12xM8 sur Ø482	12xM8 sur Ø482	12xM8 sur Ø482	12xM8 sur Ø482	12xM8 sur Ø482
Depth of housing internal centering diameter	LA	3	3	3	3	3	3	3	3	3
Housing length	LB ±0.15	93 (133)	120.5 (160.5)	148 (188)	175.5 (215.5)	203 (243)	230.5 (270.5)	258 (298)	285.5 (325.5)	313 (353)
Alignment rotor / housing	P ± 0.1	37 (77)	37 (77)	37 (77)	37 (77)	37 (77)	37 (77)	37 (77)	37 (77)	37 (77)
Maximum rotoric contact diameter	Pmax	384	384	384	384	384	384	384	384	384
Rotor length	R +0.15	27.5	55	82.5	110	137.5	165	192.5	220	247.5

INTEGRATION :

- ✓ The cables are made of PU, class 6, foreseen for cable-bearing chains, 2 mt standard length, copper square section according rated current.
- ✓ Rotor / housing alignment (P) has to be executed within +/- 0.1 mm. Optionally, we can supply a mounting tool for achieving that alignment in case of assembly without possibility of accurate alignment.
- ✓ Thermal device cable consists of a shielded pair 2x2x0.25mm² section, 7mm external diameter.
- ✓ (De) represents:
 - 1- The maximum diameter passing inside the housing.
 - 2- The maximum diameter necessary for rotor assembly.
- ✓ (Pmax) diameter for pieces in contact with the rotor must never be exceeded.
- ✓ Tapped holes on each side of rotor and housing are angularly aligned.
- ✓ Cable positioning (AF) is theoretical. Leave a free room with a +/- 10 arc degrees tolerance around that position, on a 50 mm height from the housing side, for avoiding to force the cables at the alternator output.
- ✓ When designing the assembly, take care to insure a perfect contact between housing and user's bore for avoiding thermal problems.
- ✓ For housing mounting, use either external centering diameter (B) or internal centering diameters (A).
- ✓ For execution tolerances (perpendicularity, concentricity...), please consult us.
- ✓ In red in the table : P, LB, J4 and E3 are 30mm wider when the nominal current is greater than 72 amps (four single wires output)

A full integration handbook can be supplied to our customers upon request
For further information or specific request about our alternators, feel free to contact us.

TECHNICAL CHARACTERISTICS

800 STK ALTERNATORS

		800STK2M		800STK4M		800STK6M	
Rated speed	Rpm	80	400	80	400	80	350
Rated power (1)(2)	W	6999	48860	15253	84509	23013	98974
Current at rated speed (1)	Amps	17.6	122.4	38.2	211.8	57.7	252.0
Voltage at rated power (1)(2)(3)	V	133	133	133	133	133	133
Power at half speed (1)(2)	W	2593	22389	6047	42600	9380	52600
Phase resistance at 20°C	Ohm	1.59	0.06	0.55	0.02	0.31	0.01
Phase inductance	mH	14.28	0.56	6.97	0.23	4.63	0.19
Phase emf at 20°C (4)	V	187.9	185.3	185.5	167.4	184.4	161.8
Rotor inertia	10 ⁻³ Kg.m ²	2.54	2.54	5.08	5.08	7.62	7.62
Weight	Kg	82	82	138	138	193	193
Power cable square section	mm ²	4x2.5	4x35	4x6	4x70	4x16	4x95

800 STK Generators Power - Speed

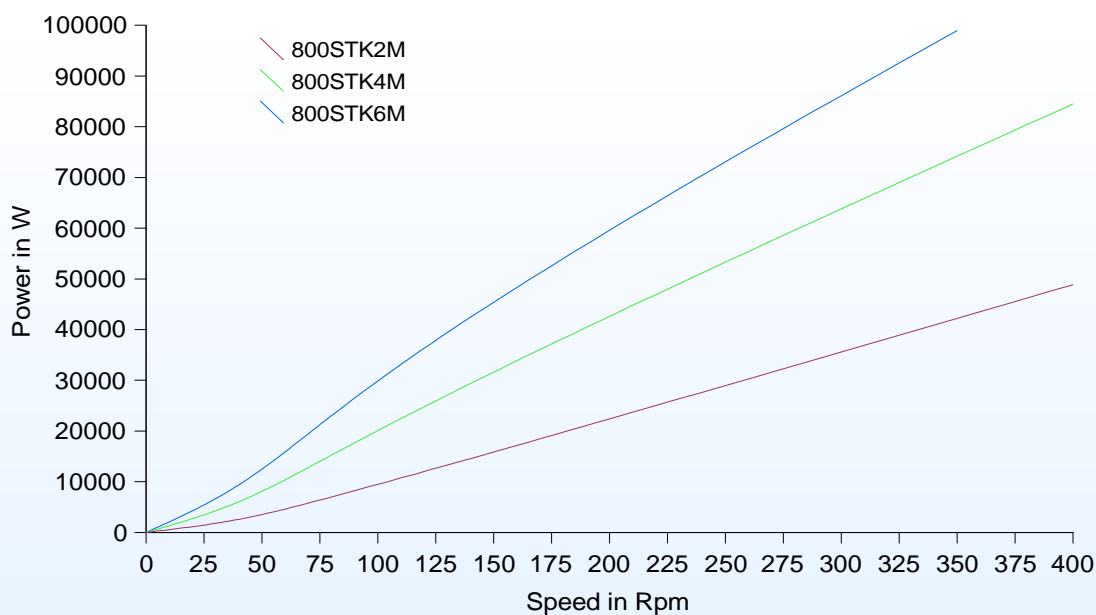

- (1) Ambient temperature 40°C
 Wind speed 10 m/s
 Winding temperature rise < 100°C
 Stator housing in contact with the ambient air or integral on all its peripheral area with a metallic armature in contact with the ambient air
 Stator housing secured on a metallic frame getting an area equal to twice the cross section of the housing
- (2) Operation with unitary power factor
- (3) Single voltage, voltage is 230Vac phase to phase. Voltage level may be adapted according to the application
- (4) Alternator at no load and rated speed

ALTERNATORS 800 STK

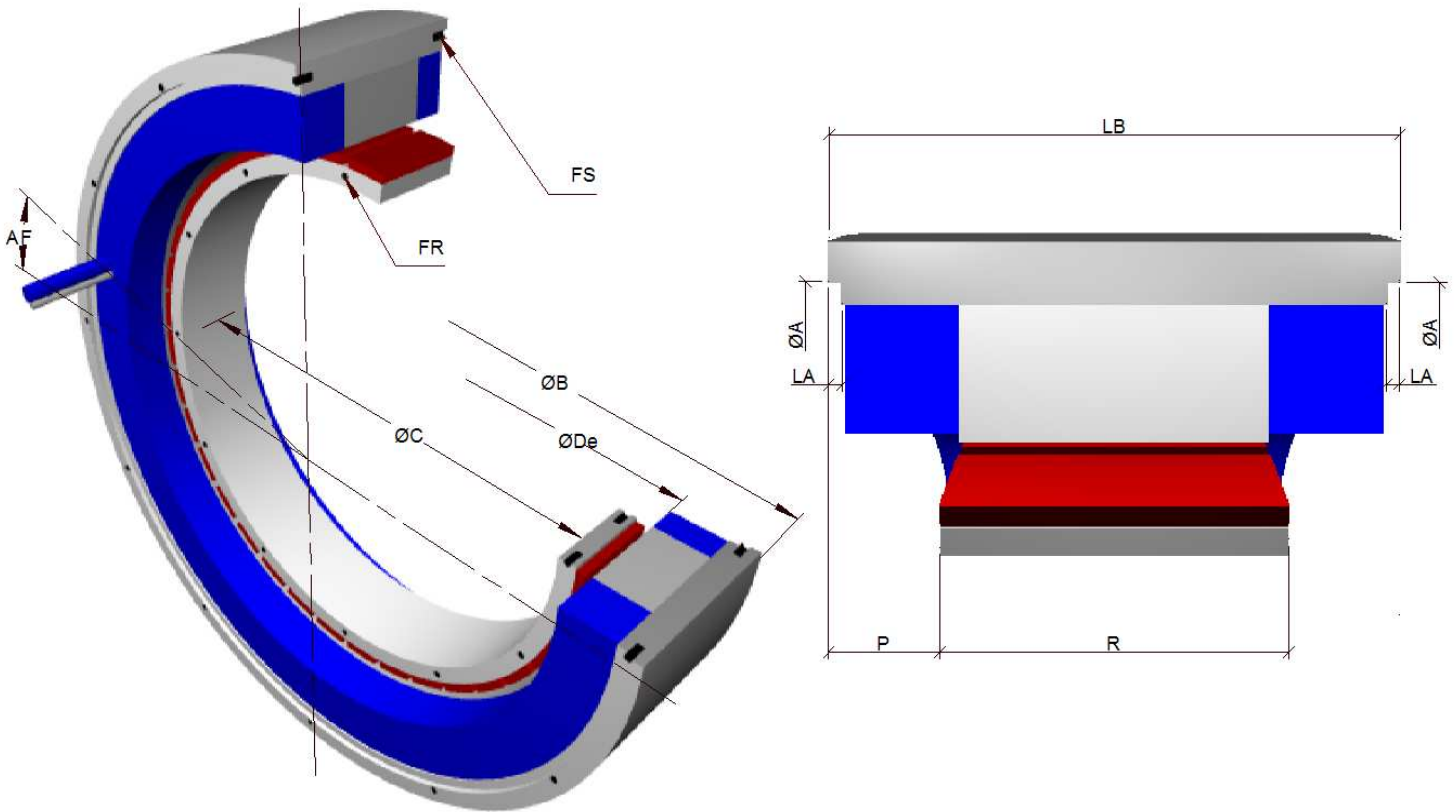

		800STK1M	800STK2M	800STK3M	800STK4M	800STK5M	800STK6M
Housing internal centering diameter	A H8	762	762	762	762	762	762
Angle wire output / tapped holes	AF	11.25	11.25	11.25	11.25	11.25	11.25
Housing external centering diameter (natural convection)	B H7	795	795	795	795	795	795
Rotoric internal centering diameter	C H7	630	630	630	630	630	630
Housing internal diameter	De	689	689	689	689	689	689
Rotoric fixation holes	FR	16xM8 on Ø645	16xM8 on Ø645	16xM8 on Ø645	16xM8 on Ø645	16xM8 on Ø645	16xM8 on Ø645
Housing fixation holes	FS	16xM8 on Ø774	16xM8 on Ø774	16xM8 on Ø774	16xM8 on Ø774	16xM8 on Ø774	16xM8 on Ø774
Depth of housing internal centering diameter	LA	5	5	5	5	5	5
Housing length	LB ±0.15	112.5 (152.5)	140 (180)	167.5 (207.5)	195 (235)	222.5 (262.5)	250 (290)
Alignment rotor / housing	P ± 0.2	47 (87)	47 (87)	47 (87)	47 (87)	47 (87)	47 (87)
Maximum rotoric contact diameter	Pmax	666	666	666	666	666	666
Rotor length	R +0.15	27.5	55	82.5	110	137.5	165

INTEGRATION :

- ✓ The cables are made of PU, class 6, foreseen for cable-bearing chains, 2 mt standard length, copper square section according rated current.
- ✓ Rotor / housing alignment (P) has to be executed within +/- 0.2 mm. Optionally, we can supply a mounting tool for achieving that alignment in case of assembly without possibility of accurate alignment.
- ✓ Thermal device cable consists of a shielded pair 2x2x0.25mm² section, 7mm external diameter.
- ✓ (De) represents:
 - 1- The maximum diameter passing inside the housing.
 - 2- The maximum diameter necessary for rotor assembly.
- ✓ (Pmax) diameter for pieces in contact with the rotor must never be exceeded.
- ✓ Tapped holes on each side of rotor and housing are angularly aligned.
- ✓ Cable positioning (AF) is theoretical. Leave a free room with a +/- 10 arc degrees tolerance around that position, on a 50 mm height from the housing side, for avoiding to force the cables at the alternator output.
- ✓ When designing the assembly, take care to insure a perfect contact between housing and user's bore for avoiding thermal problems.
- ✓ For housing mounting, use either external centering diameter (B) or internal centering diameters (A).
- ✓ For execution tolerances (perpendicularity, concentricity...), please consult us.
- ✓ In red in the table : P and LB are 30mm wider when the nominal current is greater than 72 amps (four single wires output)

A full integration handbook can be supplied to our customers upon request
 For further information or specific request about our alternators, feel free to contact us.

Join **ALXION** on its WEB site: <http://www.alxion.com>

Our site allows you to keep up with our products evolution, to download technical information or catalogues on your computer, to send us messages by e-mail.

Keep in touch with us: Surf on our bilingual site!



ACCESS TO OUR HEAD OFFICE

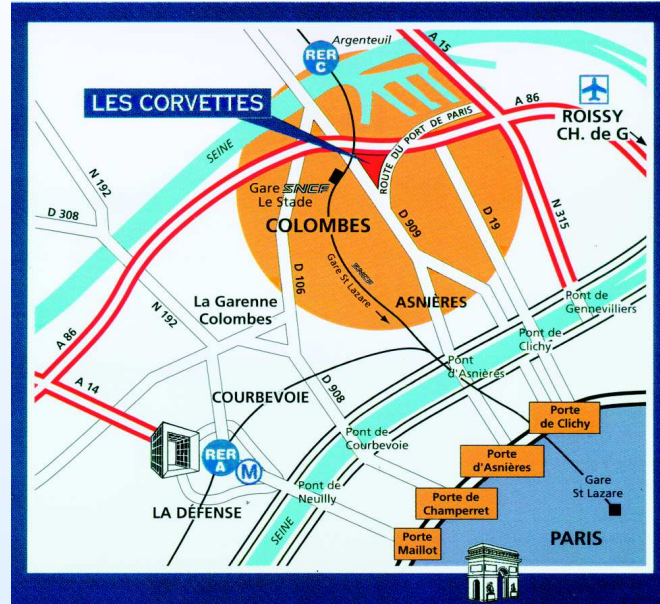

ALXION
Automatique
& Productique

Head Office: Parc Technologique "Les Fossés Jean"
142-176, Avenue de Stalingrad
F - 92712 COLOMBES Cedex
Phone: (33) 1 41 30 63 04
Fax: (33) 1 41 30 61 36
Web site: <http://www.alxion.com>